

# Installation Guide

## StoTherm<sup>®</sup> ci Mineral

November 2018

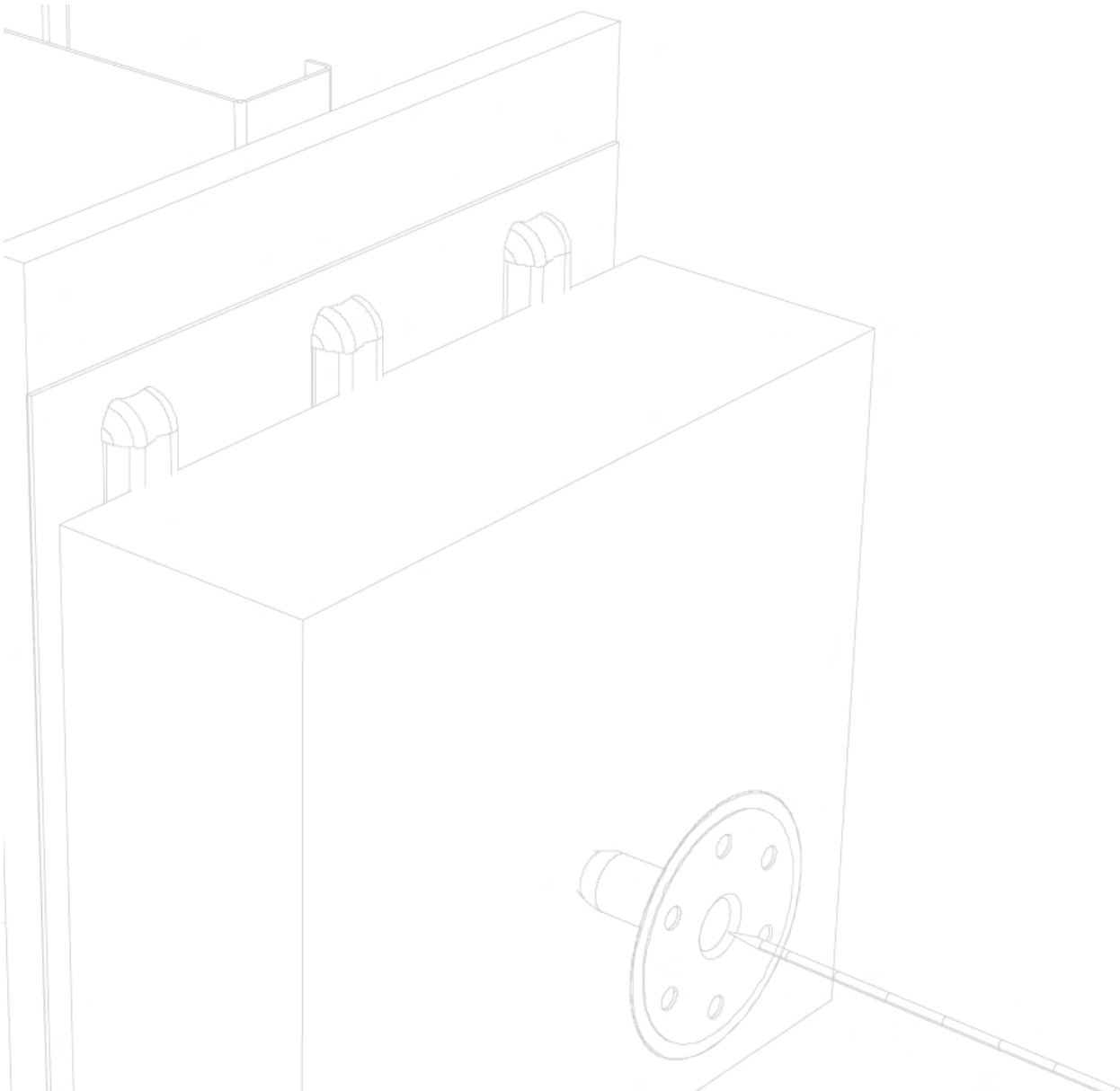

### ATTENTION

Sto products are intended for use by qualified professional contractors, not consumers, as a component of a larger construction assembly as specified by a qualified design professional, general contractor or builder. They should be installed in accordance with those specifications and Sto's instructions. Sto Corp. disclaims all, and assumes no, liability for on-site inspections, for its products applied improperly, or by unqualified persons or entities, or as part of an improperly designed or constructed building, for the nonperformance of adjacent building components or assemblies, or for other construction activities beyond Sto's control. Improper use of Sto products or use as part of an improperly designed or constructed larger assembly or building may result in serious damage to Sto products, and to the structure of the building or its components.

STO CORP. DISCLAIMS ALL WARRANTIES EXPRESSED OR IMPLIED EXCEPT FOR EXPLICIT LIMITED WRITTEN WARRANTIES ISSUED TO AND ACCEPTED BY BUILDING OWNERS IN ACCORDANCE WITH STO'S WARRANTY PROGRAMS WHICH ARE SUBJECT TO CHANGE FROM TIME TO TIME. For the fullest, most current information on proper application, clean-up, mixing and other specifications and warranties, cautions and disclaimers, please refer to the Sto Corp. website, [www.stocorp.com](http://www.stocorp.com).

### Sto Corp.

3800 Camp Creek Pkwy SW  
Building 1400 • Suite 120  
Atlanta, Georgia 30331 USA  
Phone (800) 221-2397

[www.stocorp.com](http://www.stocorp.com)



# TABLE OF CONTENTS

<b>Introduction.....</b>	<b>3</b>
Substrates.....	3
Surface Preparation/Mockups.....	3
Curing and Drying.....	3
<b>System Components.....</b>	<b>4</b>
<b>Product List.....</b>	<b>5</b>
Batch Numbers.....	6
<b>Specialty Tools.....</b>	<b>6</b>
<b>Material Storage and Handling.....</b>	<b>7</b>
<b>Health and Safety.....</b>	<b>7</b>
<b>Air and Moisture Barrier Installation.....</b>	<b>8</b>
Rough Opening Treatment.....	8-10
Joint Treatment.....	11-12
Transition Details.....	13-15
Air and Moisture Barrier Coating.....	16
<b>Mineral Wool Installation.....</b>	<b>17</b>
System Terminations.....	17-18
Adhesive Application.....	19
Mineral Wool Placement.....	19
Mechanical Fasteners.....	20, 23-24
Thermal Dowel Patterns.....	21-22
<b>Aesthetics.....</b>	<b>25</b>
<b>Base Coat Application.....</b>	<b>27</b>
Backwrapping.....	27
Outside Corners.....	28
Inside Corners.....	28
Reveals.....	29
Base Coat Installation with Mesh Reinforcement.....	30
Skim Coat.....	30
<b>Finish Application.....</b>	<b>31</b>
<b>Precautions and Limitations.....</b>	<b>33</b>

# 1. INTRODUCTION

The StoTherm® ci Mineral System is a decorative and protective exterior wall cladding that combines superior air and weather tightness with excellent thermal performance and fire resistance. It incorporates noncombustible continuous exterior insulation and a continuous air and moisture barrier with Sto's high performance finishes to produce an advanced high performance wall cladding assembly. This guide is intended for contractors as an aid for proper installation of the system.

**NOTE:** This guide is intended for new construction only. For retro-fitting or restoration, refer to the Sto reStore Guide. For design guidance, refer to the StoTherm ci Mineral Design Guide.

## Substrates:

- Glass mat faced gypsum sheathing in compliance with ASTM C1177
- Exterior or Exposure 1 wood based sheathing – plywood and OSB – in conformance with U.S. Product Standard PS-1.
- Concrete and concrete masonry surfaces

## Surface Preparation/Mock-ups:

Apply materials only to clean, sound, dry, fully cured, properly prepared, frost free surfaces. Surfaces must be free of damage, structurally sound and free of bond-inhibiting materials, including grease, dust, dirt, oil, efflorescence, form release oil, and any other foreign matter or surface contamination.

Where surfaces do not conform, correct the condition before proceeding with work and construct a mock up under actual conditions of use to verify proper surface preparation.

The mock up should also serve to verify proper means and methods of application, material coverage rates, interface details with other components of construction for proper functioning of the wall assembly, standard of care in work and aesthetics.

## Curing and Drying:

**Pail (wet) products:** Product dries within 24 hours under normal drying conditions (70°F [21°C], 50% RH). Final drying time varies depending on temperature/humidity, thickness of application, surface conditions, and other variables that may exist. Cold weather and/or damp conditions prolong drying. Hot weather and/or dry conditions accelerate drying. Protect product from rain, freezing, and continuous high humidity until completely dry.

**Cartridge or Sausage (sealant-like) products:** Product is moisture cure. Tack free time is 30 minutes and drying time is within 4 hours under normal (70°F [21°C], 50% RH) conditions and relative humidity. Drying time is slower with low temperature/low humidity and faster with high temperature/high humidity.

**Dry (bag) products:** Product dries within 24 hours under normal drying conditions (70°F [21°C], 50% RH). Final drying time varies depending on temperature/humidity, thickness of application, surface conditions, and other variables that may exist. Cold weather and/or damp conditions prolong drying. Hot weather and/or dry conditions accelerate drying. Protect product from rain and freezing until completely dry.

**NOTE:** Always refer to label on packaging for additional information that may apply.

## 2. System Components

- 1 Substrate (by others)
- 2 Sto Gold Coat Air & Moisture Barrier
- 3 Sto BTS Plus Adhesive
- 4 Owens Corning Thermafiber® CI-C SC18 Mineral Wool Insulation Board
- 5 Sto Thermo Dowel
- 6 Sto Mesh (embedded in Sto Base Coat)
- 7 Sto BTS Plus Base Coat
- 8 StoPrime Sand (optional)
- 9 Sto Textured Finish

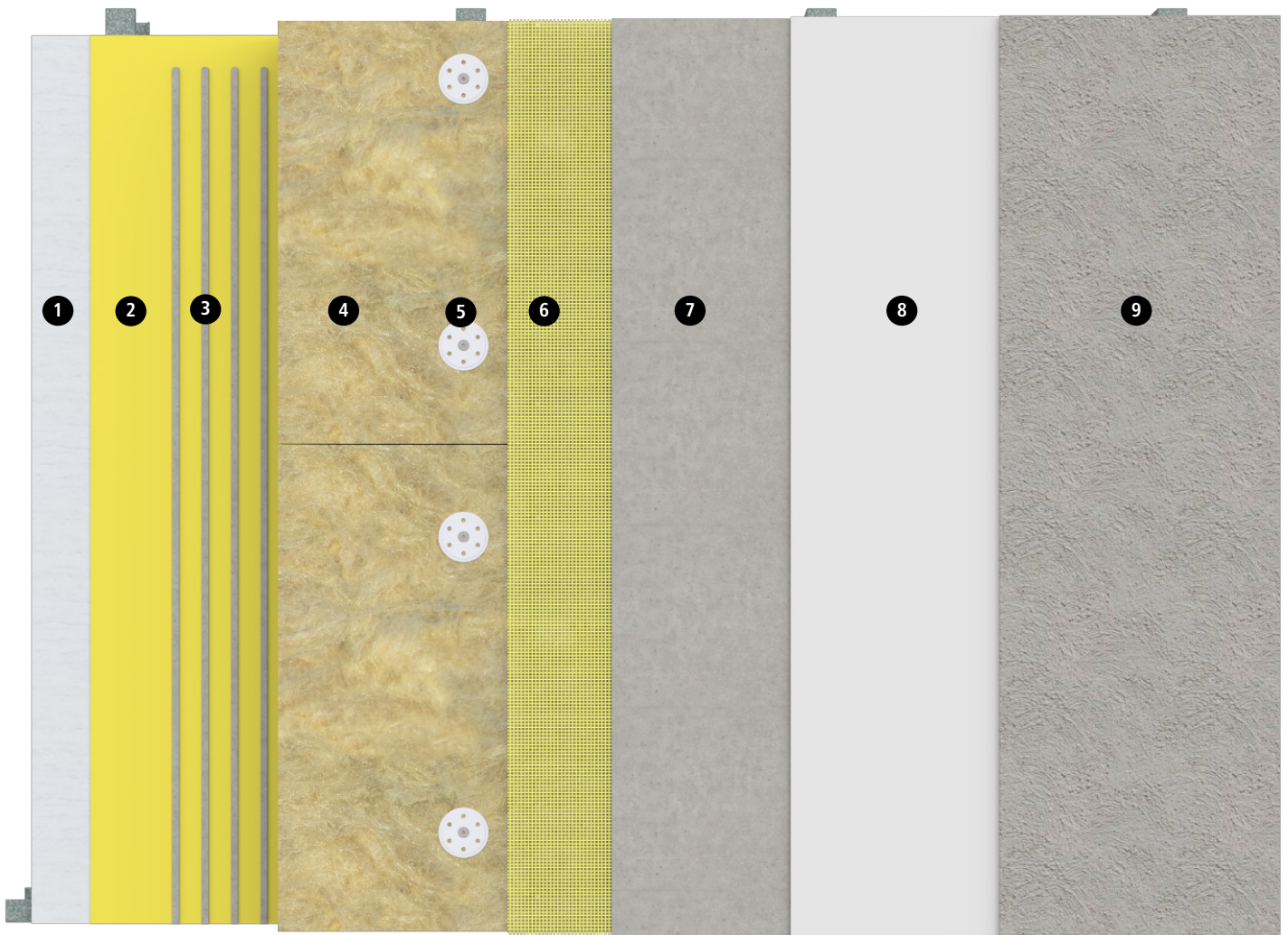

### 3. Product List



**Owens Corning Thermafiber CI-C SC18 Mineral Wool:** Non combustible ASTM C612 compliant mineral wool insulation board, specially designed for use with Sto materials.



**Sto Gold Coat® :** Roller or spray applied vapor-permeable air & moisture barrier.



**Sto Air Seal™ :** Roller or spray applied, medium or high build, vapor-permeable air & moisture barrier.



**Sto VaporSeal™ -** Roller or spray applied high build air barrier and Class 1 vapor retarder (< 0.1 perms). Provides superior protection against vapor diffusion, moisture intrusion, and air leakage.



**Sto RapidGuard™ :** One-component air barrier and waterproof material used to protect rough openings, sheathing joints, seams, cracks, penetrations, and other transitions.



**Sto Gold Fill® :** Trowel applied joint treatment and air barrier material used to treat rough openings, corners, and sheathing joints with StoGuard® Mesh or Sto Detail Mesh.



**StoGuard® Mesh:** Glass fiber, self-adhesive mesh for use with Sto Gold Fill and Sto Gold Coat TA as part of the StoGuard assembly.

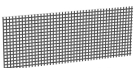

**StoGuard® Fabric:** Non-woven cloth reinforcement to treat joints, inside and outside corners and rough openings when embedded in Sto Gold Coat, Sto AirSeal or Sto VaporSeal.

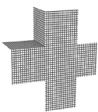

**StoGuard® RediCorner:** A preformed fabric piece used in the corners of rough openings for quicker installation.



**StoGuard® Transition Membrane:** Flexible air barrier material used to make connections with adjoining construction to achieve continuity of the air barrier assembly at dynamic joints and dissimilar materials.



**Sto BTS Plus:** One-component, polymer modified portland cement based material used as an adhesive and base coat.

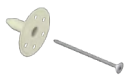

**Sto Thermo Dowel:** Used to attach the mineral wool insulation boards and designed to eliminate or minimize thermal bridging.



**Sto - Mesh Corner Bead:** Provides a solution to create true and straight corners which are resistant to chipping and cracking in StoTherm® ci wall systems.



**Sto Mesh, Sto Mesh 6.0 oz, Sto Intermediate Mesh:** Specially designed coated glass fiber meshes used for impact resistance in Sto claddings

## Batch Numbers (examples)

Refer to individual product bulletins for shelf life.

### Wet and Dry Products:

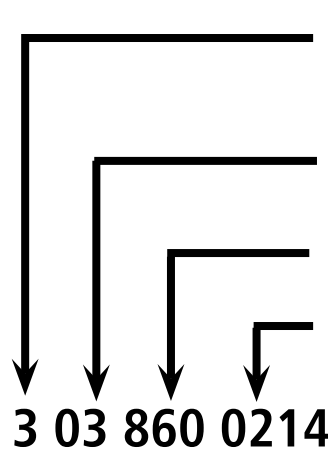
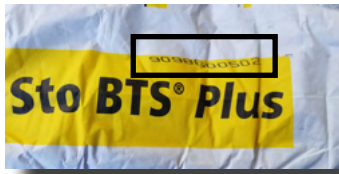

"3" is the last digit of the year of expiration, in this case, the year 2013.

"03" is the month of expiration, or, the month of March.

"860" is the plant code

The last four digits are a sequential batch number tied to the formula, production and testing records for the specific batch.

### Cartridge or Sausage (sealant-like) Products:

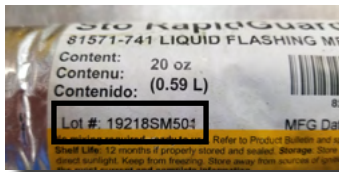

Lot #: 19218SM501

"192" indicates the date of production based on the Julian calendar, in this case, the 192nd day of the year or July 11.

"18" indicates the year of production.

"SM501" indicates production and testing records for the specific batch.

## Specialty Tools Needed:



Serrated knife

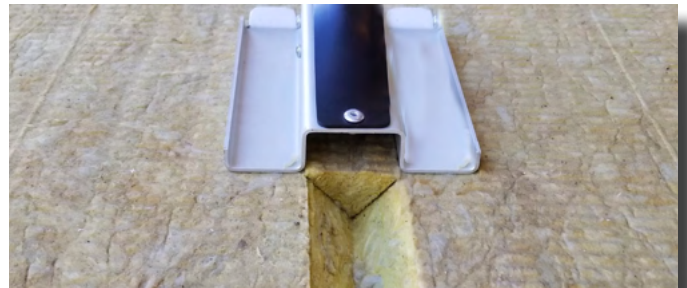

Reveal Cutter



Notched Trowel



Sto Thermo Countersunk Tool

## Material Storage and Handling

Below is a summary of general guidelines for storage and handling of Sto products. Refer to product bulletins or labels on packaging for product specific information:

- Pail (wet) products: store in a cool, dry area. Protect from extreme heat (90°F [32°C]), freezing, and direct sunlight.  
Apply only when surface and ambient temperatures are between 40°F and 100°F (4°C and 37.8°C) during application and drying period. Do not apply to frozen surfaces. Do not apply if the surface temperature is less than 5°F (2.8°C) above the ambient dew point temperature.

**NOTE:** Some specialty finishes may have more stringent requirements. Refer to label on packaging.

- Bag (dry) products: store off the ground in a cool, dry location. Protect from moisture, extreme heat (90°F [32°C]), freezing, and direct sunlight. Apply only when surface and ambient temperatures are between 40°F and 100°F (4°C and 37.8°C) during application and drying period.
- Cartridge or Sausage (sealant-like) products: store in a cool (less than 80°F [26.7°C]), dry area. Protect from heat, freezing, moisture, and direct sunlight. Store away from sources of ignition. Apply only when surface and ambient temperatures are between 35°F and 100°F (0.6°C and 37.8°C) during application and drying period.
- Mineral Wool Insulation Board: store off the ground in a dry location with adequate ventilation. Protect from direct sunlight.
- Other (Cartons - meshes, fabrics, tapes, transition membrane): store cartons flat off the ground in a dry location. Protect from direct sunlight. Store mesh roll cartons flat (not upright).

**NOTE:** Always refer to label on packaging for additional information that may apply.

## Health and Safety

Refer to Product Bulletins and Safety Data Sheets at [www.stocorp.com](http://www.stocorp.com).

# 4. Air and Moisture Barrier Installation

**StoGuard** is the air and moisture barrier component of StoTherm ci Mineral. It is comprised of multiple compatible components that protect rough openings, treat sheathing joints, and transition to other components of construction (e.g., flashing) or span across joints and seams in construction (e.g., expansion joints, dissimilar materials). These StoGuard “detail” components are top coated with a StoGuard air and moisture barrier coating (p.16).

**IMPORTANT**

The combination of detail components and top coat provides a seamless air and moisture barrier that contributes to the air tightness of the building envelope and protects substrates from moisture infiltration during construction and in the event of a breach of the wall cladding while in service. In order for the the air and moisture barrier to be fully effective it must be continuous. This means it must be connected with other air and moisture barrier components within the building envelope, for example, connected to foundation waterproofing, windows, and roof membrane. Construction sequencing must be planned to enable proper connections, and compatibility with other air barrier components must be taken into account.

## ■ Rough Opening Protection

### Option 1: Sto RapidGuard (applied to a thickness of 12-20 wet mils)



Figure 1

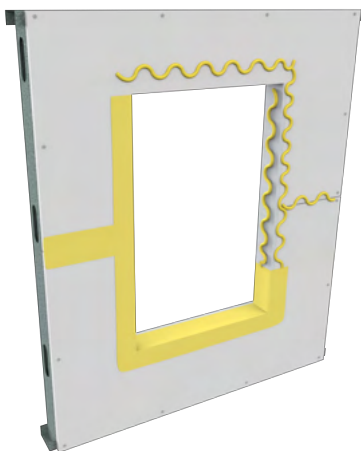

Figure 2

**Sto RapidGuard™** is a single-component, multi-use air barrier and waterproof material used to seal rough openings (including complex rough openings with wood bucks), sheathing joints, seams, cracks and transitions.

1. Apply a bead of Sto RapidGuard with a caulking gun at the seams of the four corners inside the rough opening.
2. Then apply material liberally with a caulking gun in a zig-zag pattern into the rough opening and around the perimeter (Figure 1).
3. Spread the material to a uniform thickness of 12-20 wet mils (0.3-0.5mm) inside the opening and 2" (51mm) minimum onto the face of the sheathing all the way around before the material skins (Figure 2) to achieve a VOID AND PINHOLE FREE SURFACE.
4. It is not necessary to top coat Sto Rapid Guard with a Sto air and moisture barrier coating. If top coating, do so within 48 hours for best adhesion.

**NOTE:** Sto RapidGuard is chemically compatible with most silicone and urethane sealants. Always verify adhesion with field tests.



## ■ Rough Opening Protection

### Option 2: StoGuard Fabric and StoGuard RediCorners

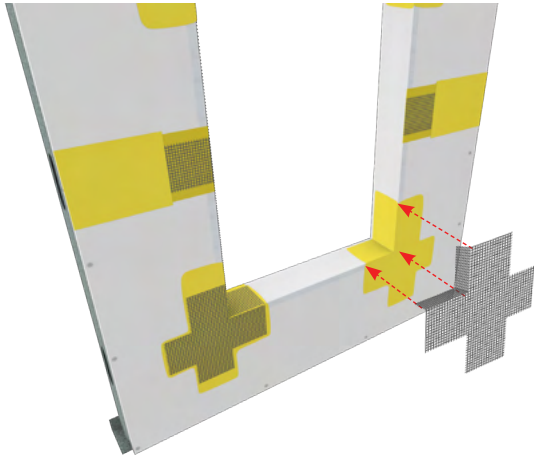

Figure 3

#### Corners:

1. Apply the air and moisture barrier coating liberally with a roller or airless spray equipment.
2. Place pre-formed corner pieces in the wet coating on the inside of the rough opening with the tabs oriented so that they are on the face of the sheathing (Figure 3).
3. Embed the corner pieces in the coating with a brush or roller and smooth any wrinkles. Repeat for all corners.

#### Sill, Jamb, and Head:

1. Apply the air and moisture barrier coating liberally with a roller or airless spray equipment.
2. Pre-cut 6" (152mm) wide fabric pieces (for 2x4 construction) or 9" (229mm) fabric (for 2x6 construction) that are slightly shorter than the lengths of the sill, jamb, and head.
3. Center the lengths of pre-cut fabric pieces (Figure 4) at the corresponding location (sill, jamb, or head) of the opening and place in the wet coating.
4. Overlap corner pieces minimum 2" (51mm) and fold onto the face of the sheathing minimum 2" (51mm).
5. Embed the fabric in the air and moisture barrier coating with a brush or roller and smooth any wrinkles.
6. Allow the rough opening application to dry. When applying the air and moisture barrier coating (p. 16) to the entire wall surface, include the area inside the rough opening.

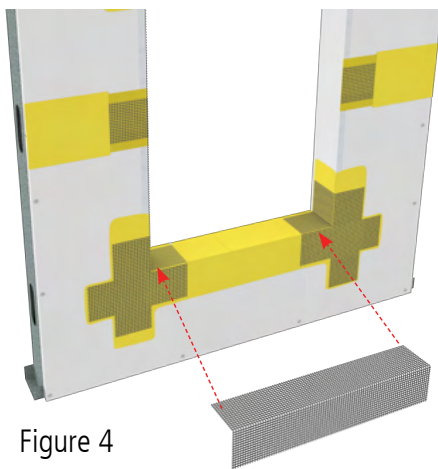

Figure 4

#### NOTE

Where the opening requires use of multiple pieces of fabric, overlap the fabric onto the previously placed section a minimum of 2" (51mm) by applying the air and moisture barrier coating liberally to the overlap area and embedding the overlap fabric in coating.

Check for pinholes, thin spots, wrinkles, and fish mouths in the fabric and correct these conditions if they exist. A VOID AND PINHOLE FREE SURFACE must be achieved. The final installation must provide a continuous coating and fabric along the rough opening surface and extend onto the face of the sheathing minimum 2" (51mm). Allow coating to dry before proceeding to the next step.

### Option 3: Sto Gold Fill with StoGuard Mesh

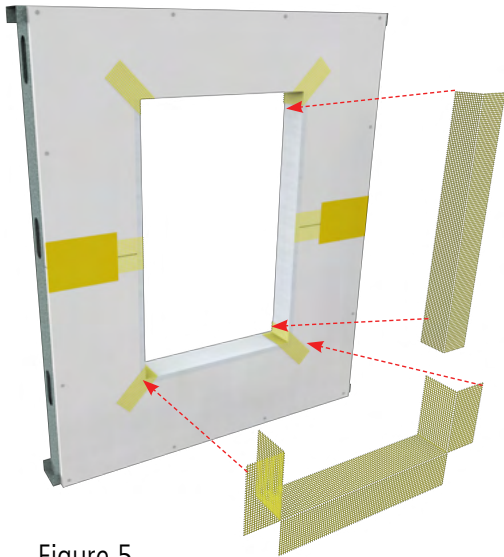

Figure 5

1. Apply a 2" (51mm) wide strip of mesh lapping onto the face of the wall diagonally at corners of opening.
2. Wrap the sill with 9" (229 mm) wide mesh and fold up onto the jambs minimum 4" (102mm).
3. Wrap jambs with minimum 9" (229mm) wide mesh and lap the "fold-ups" on the jambs minimum 2-1/2" (64mm) (Figure 5).
4. Wrap the head with minimum 9" (229mm) wide mesh and fold down onto the jambs minimum 4" (102mm) and extend the head piece (above the opening) minimum 4 inches past the jambs.
5. Apply Sto Gold Fill by spray or trowel over the mesh and trowel smooth to completely hide the mesh color and pattern.
6. Allow the rough opening application to dry. When applying the air and moisture barrier coating (p. 16) to the entire wall surface, include the area inside the rough opening.

## Joint Treatment

### Option 1: Sto RapidGuard (applied to a thickness of 20-30 wet mils)

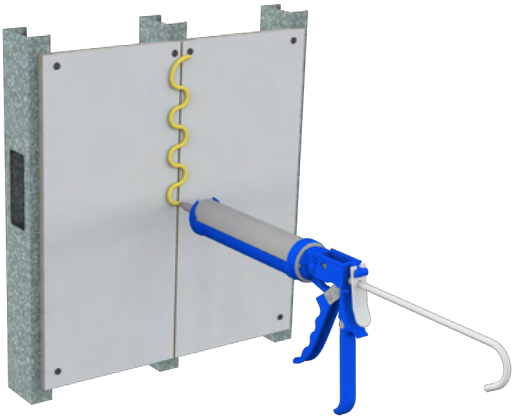

Figure 6



Figure 7

1. Apply Sto RapidGuard with a caulking gun in a zig-zag pattern over gypsum sheathing with butted joints or wood-based sheathing with gapped joints (1/8" [3mm] typical) (Figure 6).
2. Spread to a minimum width of 1" (25mm) on both sides of the joint, and to a uniform thickness of 20-30 wet mils (0.5-0.8mm) while material is still wet -usually within 2 to 3 minutes of gun application (Figure 7). Final width of the applied material is minimum 2" (51mm) centered over the joint.
3. When dry, apply the air and moisture barrier coating to the entire wall surface (p.16), including the joints.

**NOTE:** Maximum gap that can be filled with Sto RapidGuard is 1/2" (13mm). In order to conserve material, gaps may be filled with spray foam. Shave the cured foam with a scoring knife flush with the surface of the sheathing. Then treat the joints as described above.

**NOTE:** For best adhesion to the Sto RapidGuard, apply the air and moisture barrier coating (p.16) within 48 hours.

### Option 2: StoGuard Fabric



Figure 8

1. Apply 4" (102mm) wide fabric over gypsum sheathing with butted joints or wood-based sheathing with gapped joints (1/8" [3mm] typical) (Figure 8). Lap the fabric minimum 2" (51mm) at ends and embed in the air and moisture barrier coating.
2. Apply the air and moisture barrier coating liberally over the joint location with a roller or airless spray equipment slightly wider than the width of the fabric.
3. Center the fabric over the joint and place in the wet coating. Embed the fabric in the air and moisture barrier coating with a brush or roller and smooth any wrinkles in it.
4. When dry, apply the air and moisture barrier coating (p.16) to the entire wall surface, including the joints.

**NOTE:** If wood sheathing joints are in excess of 1/8" (3mm) wide fill with spray foam and shave the cured foam with a scoring knife flush with the surface of the sheathing. Then treat the joints as described above.

### Option 3: Sto Gold Fill with StoGuard Mesh

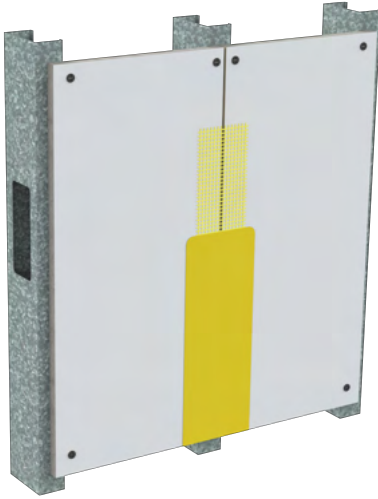

Figure 9

1. Apply minimum 4" (102mm) wide mesh centered over gypsum sheathing with butted joints or wood-based sheathing with gapped joints (1/8" [3mm] typical). Lap the mesh minimum 2-1/2" (64mm) at ends.
2. Apply Sto Gold Fill by spray or trowel over the mesh and trowel smooth to completely hide the mesh color and pattern.
3. Follow the same procedure for inside and outside corners except use 9" (229mm) wide mesh and fold it around the corner.
4. When dry, apply the air and moisture barrier coating to the entire wall surface (p.16), including the joints.

## ■ Transition Details

### Static Transitions

#### Option 1: Sto RapidGuard

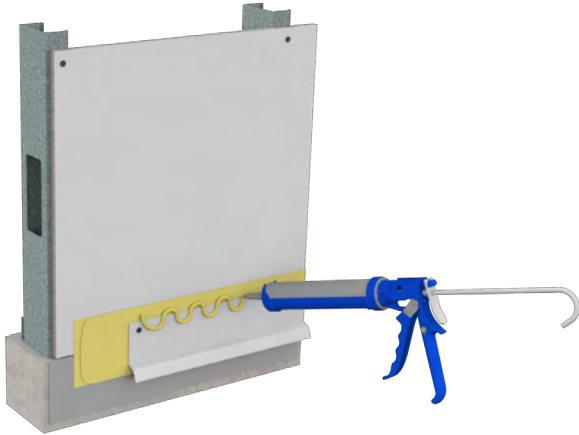

Figure 10



Figure 11



Figure 12

Static transitions are transitions where no movement is anticipated - flashing, through wall penetrations (e.g. pipes, scuppers), and static dissimilar material transitions (e.g., frame wall anchored to masonry wall, frame wall anchored to masonry slab, and sheathing to window flange).

#### **Flashing**

1. Apply material liberally with a caulking gun in a zig-zag pattern across the seam between the flashing leg and sheathing (Figure 10).
2. Spread the material across both surfaces (Figure 11) to completely seal the top of the flashing leg and to cover fasteners that attach the flashing.

#### **Penetrations**

1. Ensure a snug fit between sheathing and the penetrating element. Apply a fillet bead of material with a caulking gun around the seam between the penetrating element (e.g., pipe penetration) and the sheathing.
2. Apply additional material onto the sheathing and the penetrating element in concentric circles or in a zig-zag pattern.
3. Spread the material onto both the sheathing and the penetrating element to achieve minimum 1" (25mm) lap onto the wall surface (Figure 12) and 1/2" to 1" (13-25mm) onto the penetrating element. Create a bead profile around the penetrating element that directs water away from the wall.

## Transition Details cnt'd..



Figure 13



Figure 14

### Static Transitions

#### Option 2: StoGuard Fabric



Figure 15

### **Static Dissimilar Material Transitions**

#### **Option 1: Sto RapidGuard**

1. Apply material with a caulking gun at the seam between the two dissimilar materials (Figure 13).
2. Then apply in a zig-zag pattern on the two dissimilar materials. Spread along both surfaces to achieve minimum 2" (51mm) lap onto each surface.

**NOTE:** Ensure Sto RapidGuard edges are feathered or pulled down tight to prevent lips or ledges.

#### **Option 2: StoGuard Transition Membrane**

1. Apply the air and moisture barrier coating liberally with a roller or airless spray equipment slightly wider than the width of the transition membrane.
2. Center the transition membrane over the dissimilar materials and place in the wet coating (Figure 14). Embed the transition membrane in the air and moisture barrier coating with a brush or roller and smooth any wrinkles in it.
3. Apply an additional coat of air and moisture barrier coating to completely embed and seal the transition membrane.

### **Flashing**

1. Apply the air and moisture barrier coating liberally with a roller or airless spray equipment slightly wider than the width of the fabric.
2. Center 4" (102mm) wide fabric across the seam and place in the wet coating.
3. Embed the fabric in the air and moisture barrier coating with a brush or roller and smooth any wrinkles in it.
4. Apply an additional coat of air and moisture barrier coating to completely embed and seal the fabric over the top of the flashing leg and to cover fasteners that attach the flashing.

## Dynamic Transitions

### StoGuard Transition Membrane

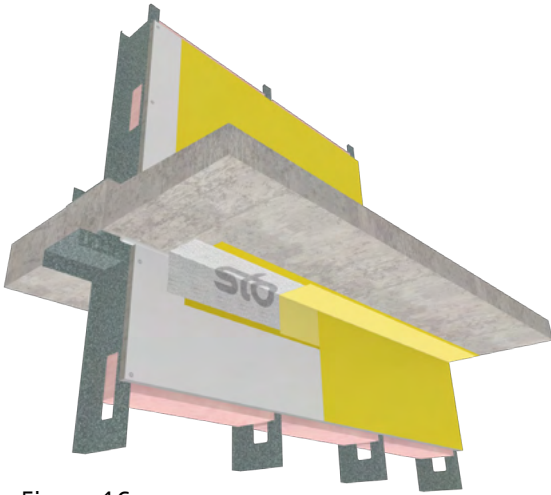

Figure 16

Dynamic transitions are transitions where movement is anticipated - expansion joints, floor line deflection joints (Figure 16), through wall joints (Figure 17).

### Dynamic Joints

1. StoGuard Transition membrane is adhered with the air and moisture barrier coating a minimum 2" (51mm) on each side of the joint.
2. Select the width of transition membrane using the formula:

**Joint Width + Anticipated Movement + 4" (102mm)**

**Example:**

For a 1" (25mm) wide joint with 1/4" (6mm) of anticipated movement:

$$1" + 1/4" + 4" = 5-1/4"$$

$$(25\text{mm} + 6\text{mm} + 102\text{mm} = 133\text{mm})$$



Figure 17

The membrane is furnished in 4-3/4" (121mm) and 6" (152mm) widths, thus the 6" (152mm) width should be selected. Always round up to the closest available width. Refer to example above.

3. Apply the air and moisture barrier coating liberally with a roller or airless spray equipment along each side of the joint slightly wider than the minimum 2" (51mm) wide adhesion area of the transition membrane.
4. Place the transition membrane in the wet coating along one side of the joint.
5. Embed the transition membrane in the air and moisture barrier coating with a brush or roller and smooth any wrinkles.
6. Tuck the membrane into the joint to create a loop (a backer rod inserted inside the joint is helpful to provide resistance and uniform depth of the loop).
7. Then place the membrane in the wet coating along the other side of the joint, embed the membrane in the coating with a brush or roller, and smooth any wrinkles. Push pins are helpful to temporarily hold the membrane in place as it is being installed and as the coating dries. After the coating is dry remove the pins and touch up the penetrations with the air and moisture barrier coating.

## ■ Air and Moisture Barrier Coating



Sheathing Joint



Outside Corner

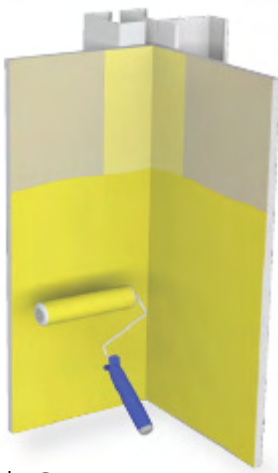

Inside Corner

The air and moisture barrier coating is a waterproof material that protects the substrate during construction and after the building is in service.

Apply the air and moisture barrier coating uniformly with a roller (see illustrations to the left) or airless spray equipment. Apply to proper wet mil film thickness and check periodically with a wet mil gage to verify proper film thickness (see Table 1 below). Apply to all sheathing surfaces and top coat all previously treated detail areas – rough openings, sheathing joints, and transitions. Allow to dry and inspect surfaces for gaps, voids, or pinholes. Apply additional material as needed to achieve a VOID AND PINHOLE FREE surface.

### IMPORTANT NOTE REGARDING CONCRETE MASONRY SURFACES:

The above instructions apply to sheathing substrates. Sto air and moisture barrier coatings may also be applied to concrete masonry (CMU) substrates using the same materials and techniques to treat rough openings and transitions. The preferred material for CMU rough openings with wood bucks is Sto RapidGuard.

The Sto air and moisture barrier coatings will function on normal weight CMU wall construction with flush joints (struck flush with the surface of the CMU) or concave joints. Thin film coatings (like Sto Gold Coat) require two liberal coats with drying between coats. Additional coats may be necessary depending on the condition of the CMU wall surface, CMU porosity, joint profile, and other variables that may exist. For “rough” CMU wall surfaces, skim coat the entire surface with one of Sto’s cementitious levelers before application of the Sto air and moisture barrier coating.

High build coatings (like Sto AirSeal and Sto VaporSeal) can generally be applied with airless spray equipment in one coat, then doubling back with a second coat after the first coat sets slightly to achieve the required wet film thickness.

**A VOID AND PINHOLE FREE SURFACE MUST BE ACHIEVED FOR THE AIR AND MOISTURE BARRIER COATING TO PROPERLY FUNCTION AS AN AIR BARRIER AND WATER BARRIER ON CMU AND OTHER WALL SURFACES.**

Table 1. StoGuard air and moisture barrier coatings and mil thickness for sheathing substrates

StoGuard Air and Moisture Barrier Coating	Total Wet Film Thickness	Total Dry Film Thickness
Sto Gold Coat	10-12	5-7
Sto AirSeal	20 for EIFS, 50 or 66	12 for EIFS, 30 or 40 as specified
StoGuard VaporSeal	80	40
Sto Gold Coat TA	26-40	20-30



# 5. Mineral Wool Installation

Owens Corning Thermafiber CI-C SC18 Mineral Wool Insulation Board is the thermal control layer. It is specifically designed for use in the StoTherm ci Mineral system and is available in 2", 3" and 4" (51mm, 76mm and 102mm) thicknesses. It achieves an R-4.0 per inch (RSI - 0.704 m<sup>2</sup>K/W).

Before installing mineral wool insulation several details must be addressed to properly terminate and encapsulate the insulation board where it abuts other components of wall construction or where it stops and starts.

## System Terminations

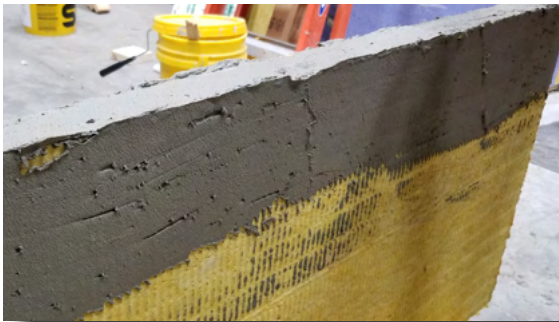

Figure 19

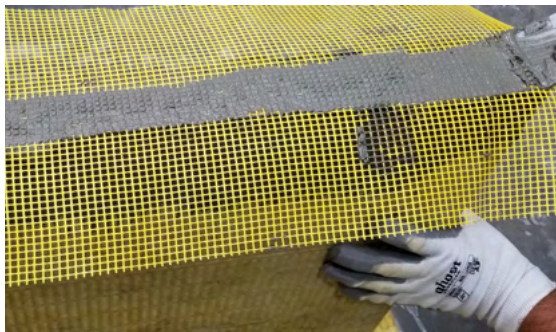

Figure 20



Figure 21

### Pre-wrapping

Pre-wrapping is a way of encapsulating and reinforcing terminating edges of the system. It is intended for use at vertical terminations and at horizontal terminations where drainage is required. At drained terminations it is used with pre-installed flashing that directs incidental water to the exterior. Pre-wrap insulation boards with Sto Mesh or Sto Detail Mesh embedded in the Sto base coat.

1. Pre-cut the mesh to the required width so that approximately 4" (102mm) is on the back of the board, plus the thickness of the board, plus a minimum of 2-1/2" (64mm) on the face of the board.
2. Apply the base coat to the insulation board along all surfaces that will receive the mesh (Figure 19).
3. Place the mesh in the wet base coat (Figure 20), and trowel smooth to completely embed the reinforcing mesh (Figure 21).
4. Use a corner trowel to achieve neat straight corners (Figure 22). Make sure no mesh color is visible after the base coat is dry. If visible apply additional base coat to completely hide the mesh color.

**NOTE:** When installing pre-wrapped insulation boards side-by-side, affix a minimum 6" (152mm) piece of backwrap mesh to the wall surface at the butt joints and complete the backwrap over the joint as explained on p.27.



Figure 22



Figure 23

### Backwrapping

Backwrapping is a way of encapsulating and reinforcing terminating edges of the system. It is intended for use at vertical terminations and other areas where drainage is not applicable.

1. Apply a strip of detail mesh to the dry air and moisture barrier (Figure 23) at vertical and other non-draining system terminations (window and door jambs, vertical expansion joints, etc.).

The mesh must be wide enough to adhere approximately 4" (102mm) of mesh onto the wall, be able to wrap around the insulation board edge and cover a minimum of 2 1/2" (64mm) on the outside surface of the insulation board. See Page 27 for remaining procedure.

## Adhesive Application



Figure 25

The adhesive in the system functions to resist gravity loads – essentially carrying or holding the weight of the insulation board. It also provides a means for draining incidental water in the event of a breach of the system by creating a narrow gap behind the insulation board with channels for drainage between the ribbons of adhesive.

1. Apply the adhesive with a ½" x ½" x 2" (13 x 13 x 51mm) U-notched stainless steel trowel.
2. Apply to the back of insulation board with the flat side of the trowel to completely cover the back of the board.
3. Then use the notched side of the trowel to form uniform ribbons of adhesive parallel to the short dimension of the board (Figure 25).

**NOTE:** Keep the trowel clean (scrape off excess adhesive) to prevent adhesive build-up between ribbons of adhesive.

## Mineral Wool Placement



Figure 26

1. After applying adhesive to the insulation, immediately place boards on the substrate in a running bond pattern so that ribbons of adhesive are oriented vertically in relation to the wall surface.
2. Use firm, even hand pressure across the board surface to secure it to the substrate (Figure 26). Keep board joints flush with one another.
3. Offset all joints in sheathing by a minimum of 8" (203mm).
4. Butt insulation board joints tightly together to prevent gaps. Use of a 6 ft (1.8m) level along the top of courses will aid in keeping courses level and board joints tight.
5. Interlock boards at inside and outside corners.

### IMPORTANT

TAKE EXTRA CARE AT THIS STAGE TO ENSURE TIGHT JOINTS AND FLUSH JOINTS. THIS WILL SAVE LABOR AND MATERIAL TO CORRECT THESE DEFICIENCIES LATER, AND WILL HELP TO ENSURE A SATISFACTORY AESTHETIC (See Section 6) IN THE FINISHED WORK.

KEEP INSULATION BOARD DRY DURING CONSTRUCTION. R-VALUE, ADHESION AND OTHER PROPERTIES CAN BE COMPROMISED IF INSULATION STAYS WET. PROTECT WITH TENTING OR BASE COAT. IF RAIN IS FORECAST OR IMMINENT, TEMPORARY PROTECTION MAY BE PROVIDED BY TAPING PLASTIC SHEETING TO THE AIR AND MOISTURE BARRIER, DRAPING IT OVER EXPOSED EDGES OF THE MINERAL WOOL, AND PINNING IT TO THE MINERAL WOOL SURFACE.

## Mechanical Fasteners

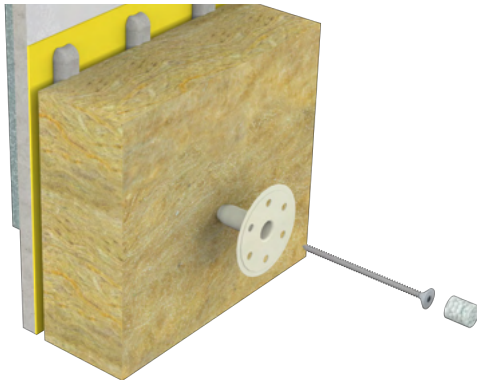

Figure 27

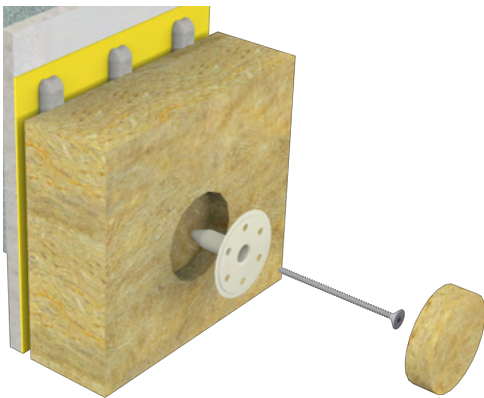

Figure 28

After insulation boards are held firmly in place with adhesive (typically 12-24 hours), insulation boards must be attached to the supporting structure with fasteners.

Sto Thermo Dowels are specially designed to minimize thermal conductivity and to reduce the risk of “telegraphing” through the finished wall surface, which sometimes occurs as the building ages because the fasteners act as thermal bridges.

- For 2” (51mm) thick insulation board, the dowels are surface-mounted and should be seated flush with the surface of the insulation. A thermal plug is then inserted into the dowel over the fastener to minimize thermal bridging (Figure 27).
- For 3” and 4” (76 and 102mm) insulation boards the dowels are countersunk into the mineral wool, approximately 3/4” (19mm) with the Sto Thermo Countersunk Tool (p.24). Sto Thermo Cap Wool is then placed over the countersunk dowel and sits flush with the mineral wool surface (Figure 28).

Select the correct fastener depending on the support structure – steel, wood, or masonry – for the system. For frame construction, 6 or 9 dowels will be used per board, depending on design wind load requirements. For solid substrates, 8 dowels per board are typically used. See p.21-22 for Sto Thermo Dowel patterns.

NOTE THAT LOCATION OF REVEALS IN THE SYSTEM MUST BE COORDINATED WITH FASTENER LOCATIONS SO THAT THEY DO NOT CROSS EACH OTHER. Reveals must be located 3” (76mm) minimum from the dowel circumference.

Table 2. Fasteners for StoTherm ci Mineral

Insulation Board Thickness	Surface Mount or Countersunk	Metal Framing	Wood Framing	Concrete
2” (51 mm)	Surface mount	2” Thermo Dowel S	2” Thermo Dowel W	not available
3” (76 mm)	Countersunk	3” Thermo Dowel S	3” Thermo Dowel W	3” Thermo Dowel C
4” (102mm)	Countersunk	4” Thermo Dowel S	4” Thermo Dowel W	4” Thermo Dowel C

### IMPORTANT

Supplemental framing may be necessary for certain conditions where the standard framing layout doesn’t correspond with the fastener layout. Metal strapping may also be used at these locations for attachment.

## Sto Thermo Dowel Patterns

Typical 16" (406mm) on center frame (steel or wood) construction with 6 dowels per board

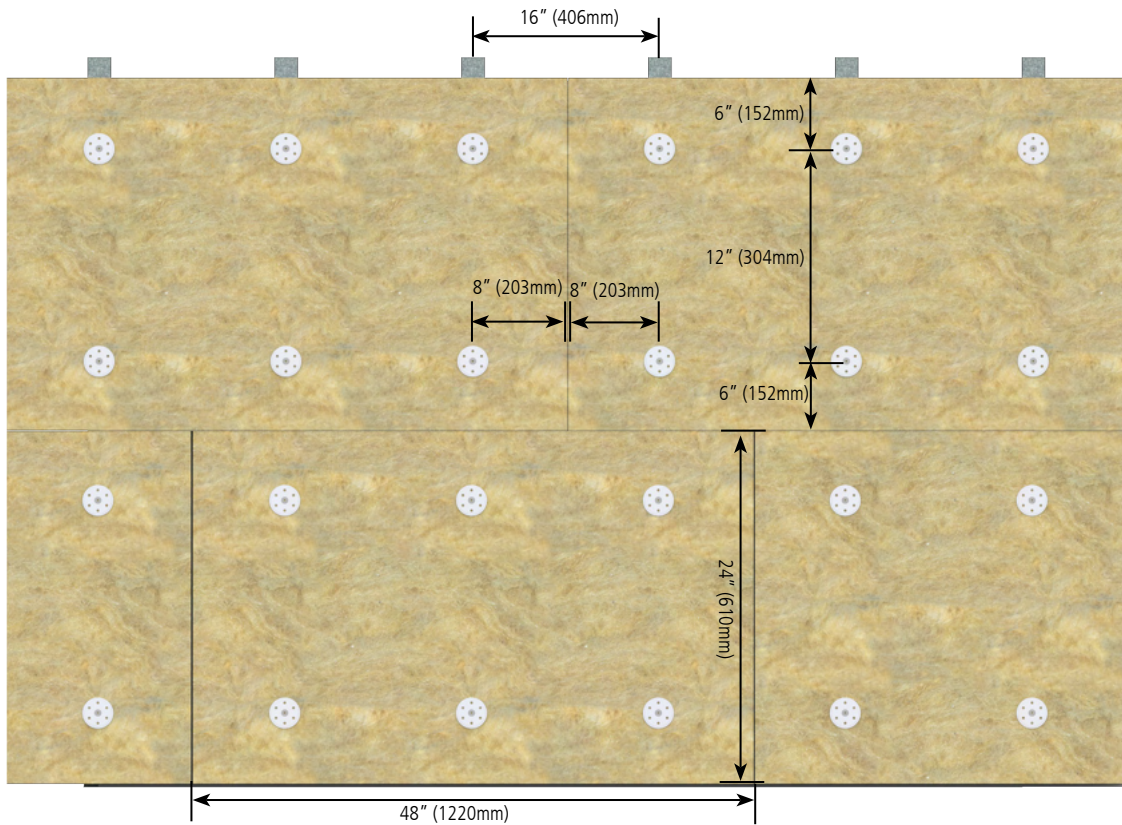

Typical 16" (406mm) on center frame construction (steel or wood) with 9 dowels per board

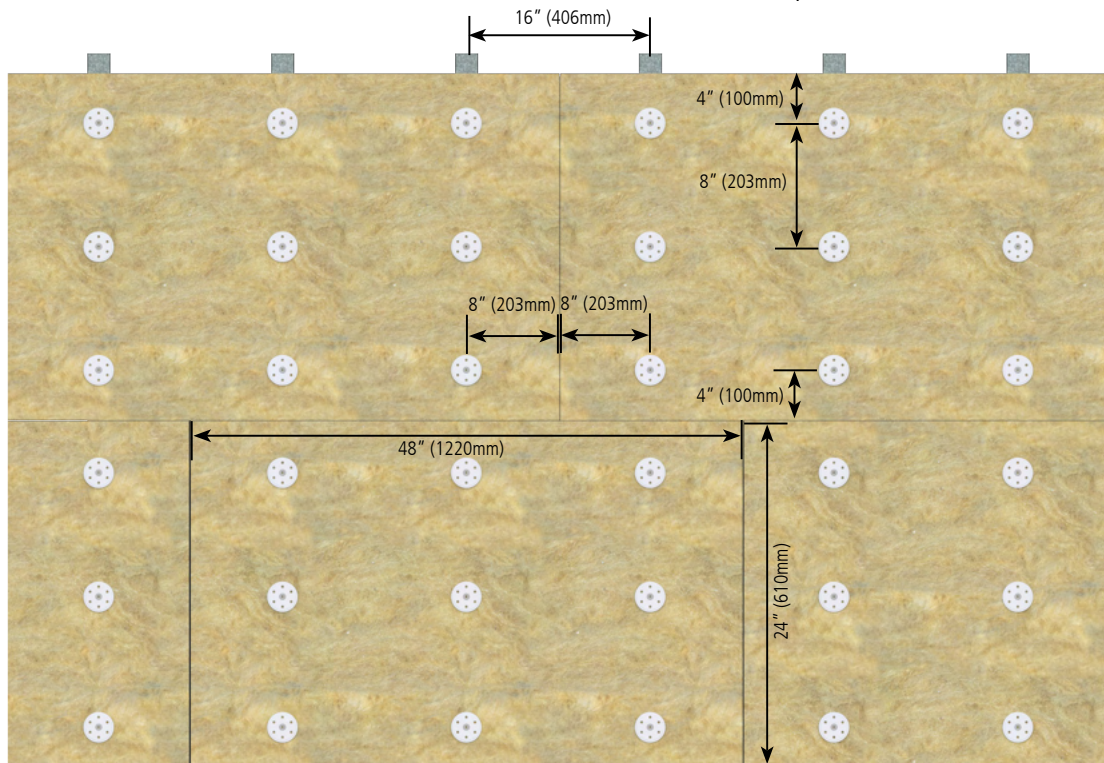

## Sto Thermo Dowel Patterns

Solid (concrete or masonry) substrate construction with 8 dowels per board

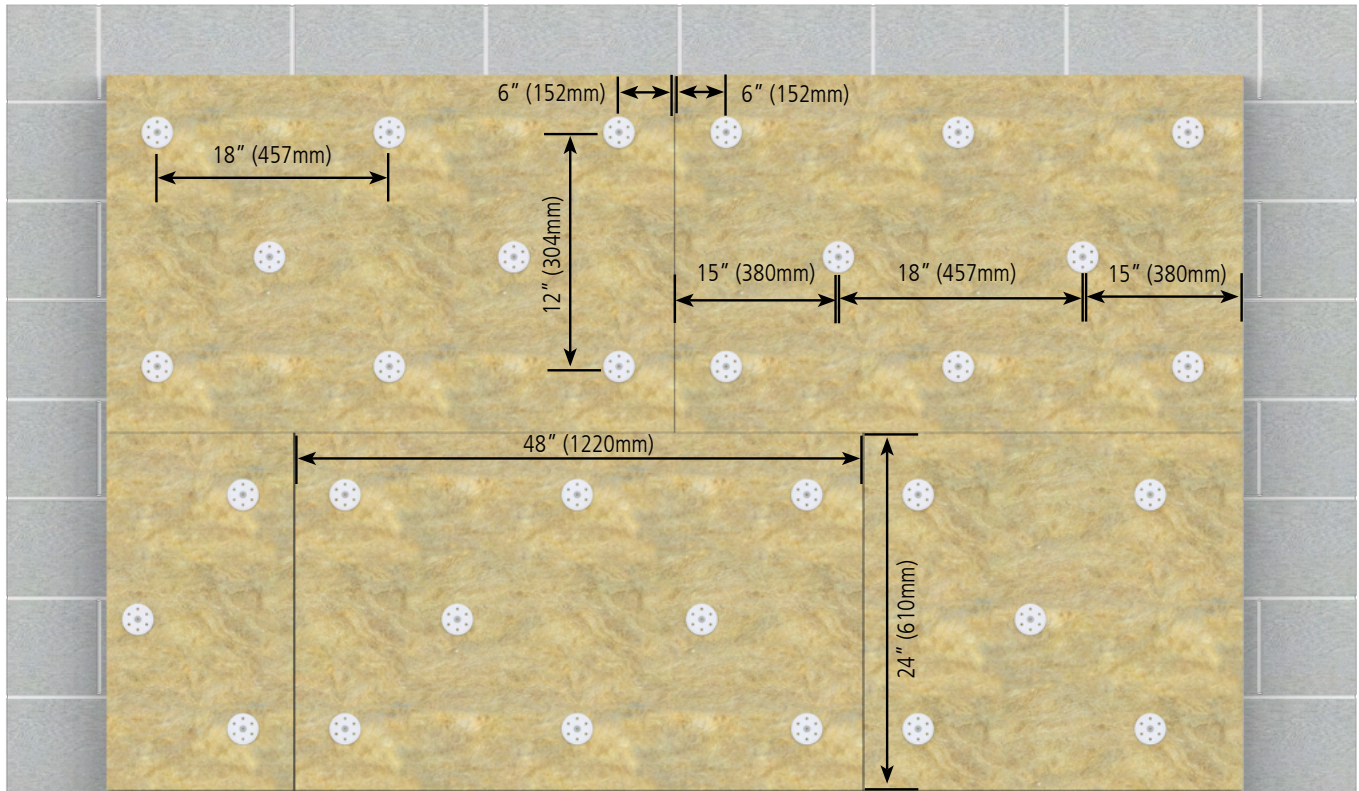

### NOTE

In general, fasteners are not the source of failure in wind load tests, as pull-out or withdrawal capacity of the fastener into minimum 18 gage steel, solid lumber, or structurally sound concrete and concrete masonry is sufficient to resist negative loads (given the Sto published fastening patterns and their ultimate wind load limits). For questionable substrates such as aged masonry with weakened mortar and/or masonry, pull out capacity of the fastener should be verified in relation to the proposed fastening pattern and wind loads. An appropriate safety factor should always be applied to establish allowable loads.

## 2" (51mm) Insulation Boards

For 2" (51mm) insulation boards, use a screw gun to drive fasteners into the supporting structure (Figures 29, 30), MAKING SURE TO COMPRESS THE DOWELS SLIGHTLY IN THE MINERAL WOOL SURFACE SO THEY ARE FLUSH WITH THE FACE OF THE INSULATION BOARD (Figure 31). If dowels are over-driven, excess base coat will be needed to fill the void which can result in cracking and increased risk of fastener/dowel "telegraphing." If dowels are seated above the surface of the insulation board they will be prone to "telegraph" in critical light because of a bump in the wall surface at the dowel location. After dowels are properly installed insert the thermal plug in the dowel recess (Figure 31), flush with the surface of the mineral wool (Figure 32). Spot all surface mounted dowels with base coat to fill any slight depressions in the surface (Figures 33, 34).

Minimum fastener penetration depths:

- Steel: minimum 3/8" (9mm) and 3 thread penetration of steel with threads engaged with steel
- Wood: minimum 3/4" (20mm) into wood framing
- Masonry: minimum 1" (25mm)



Figure 29



Figure 30



Figure 31



Figure 32



Figure 33



Figure 34

### 3" and 4" (76 and 102mm) Insulation Boards



Figure 35

For 3" and 4" (76 and 102mm) insulation boards, use a screw gun with the Sto Thermo Countersunk Tool (Figure 35) to properly countersink the Sto Thermo Dowels and to drive them into the supporting structure (Figure 36). The tool compresses the mineral wool, prevents over-driving and helps achieve the proper depth for the dowel to be countersunk. After dowels are properly countersunk, insert the Sto Thermo Cap Wool (Figure 37) in the recess, flush with the surface of the mineral wool (Figure 38).



Figure 36



Figure 37



Figure 38

#### IMPORTANT

The Sto Thermo Countersunk Tool simultaneously cuts the dowel circumference and compresses the insulation to create the recess for the dowel.



## 6. Aesthetics



Figure 39

After installing insulation board, inspect the surface for any gaps between boards or unevenness at board joints. Correcting these conditions will help to improve aesthetics of the finished work. It is recommended to correct these conditions at this stage.

### Fill Gaps

Fill gaps of 1/4" (6mm) up to 1" (25mm) between boards, with slivers of mineral wool insulation (Figure 39). For larger gaps up to 4" (100mm), attach filler pieces with adhesive. For mineral wool boards greater than 4" (100mm) in width, supplement adhesive with mechanical fasteners. Shave any excess insulation flush with the surface of the boards.



Figure 40

### Shaving

Use the straight edge of a trowel to shave any unevenness at board joints to make them flush. Shave any other protrusions or pillowing in the board surface to create a true, even wall plane (Figure 40).

### Damaged Insulation Board

1. Cut around the damaged area (Figure 41).
2. Cut a filler piece and verify that it fits tightly into the void.
3. Apply adhesive to the back of the filler piece (Figure 42) and insert into the void until it's all the way in.
4. Shave off any excess insulation so that it sits flush with the surrounding insulation (Figure 43).



Figure 41



Figure 42



Figure 43



Figure 44

### Trim

1. Add insulation board trim, 2", 3", or 4" (51, 76, or 102mm) thick over the installed insulation board.
2. Cut chamfers along insulation board edges using a straight edge cut at the desired angle with a sharp scoring knife or serrated knife. Slope the top surface of horizontal trim a minimum of 6:12 (27°) (Figure 44).
3. Attach trim with adhesive and thermal dowels and fasteners into the supporting structure. Follow the same fastening pattern as for the base layer of insulation board.
4. For sloped surfaces greater than 2" (51mm) thick, supplement the initial base coat and reinforcing mesh application with waterproof base coat embedded in Sto Mesh or Sto Detail Mesh. Extend the waterproof base coat application minimum 2-1/2" (64mm) above and below the sloped surface.

### NOTE

Another way to "create" trim is to vary mineral wool insulation board thickness. To create profiles of less than 2" (51mm), use different mineral wool insulation board thickness (e.g. use 3" (76mm) insulation and about 2" (51mm) insulation for a 1" (25mm) profile). When building trim on top of insulation, the thickness of trim is limited by available fastener lengths.



Figure 45

### Reveals

Pre-plan the location of reveals so they do not cross dowel locations or coincide with insulation board joints. Locate reveals minimum 3" (76mm) away from board joints and dowel edges.

1. Create reveals in a straight line using a straight edge and sharp reveal cutter (Figure 45).
2. Remove mineral wool insulation after cutting the reveal. Maintain a minimum 1-1/2" (38mm) insulation board thickness at the back of the reveal. The bottom surface of horizontal reveals should have a minimum 6:12 (27°) slope.

# 7. Base Coat Application

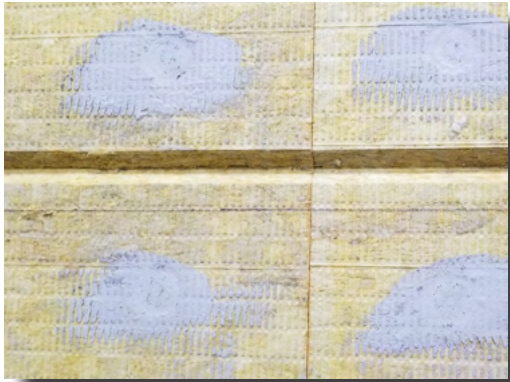

Figure 46

### Spotting Dowels

Spot all surface mounted dowels with base coat to fill any slight depressions in the surface (Figure 46).

### Filling low areas/hollows

Fill low areas in the mineral wool surface with base coat (up to 1/8" [3mm] thick).

### Backwrapping

1. Apply approximately 1/8" (3mm) thickness of base coat to the edge of the insulation board and approximately 3" (76mm) onto the face (Figure 47), then wrap the mesh around the insulation board edge and onto the face (Figure 48).
2. Press the mesh into the base coat (Figure 48) with the trowel.
3. Smooth the base coat with the trowel so the mesh is fully embedded (Figure 49). Use a corner trowel for smooth corners around edges of the board. Make sure no mesh color is visible after the base coat is dry. If visible apply additional base coat to completely hide the mesh color.



Figure 47



Figure 48



Figure 49

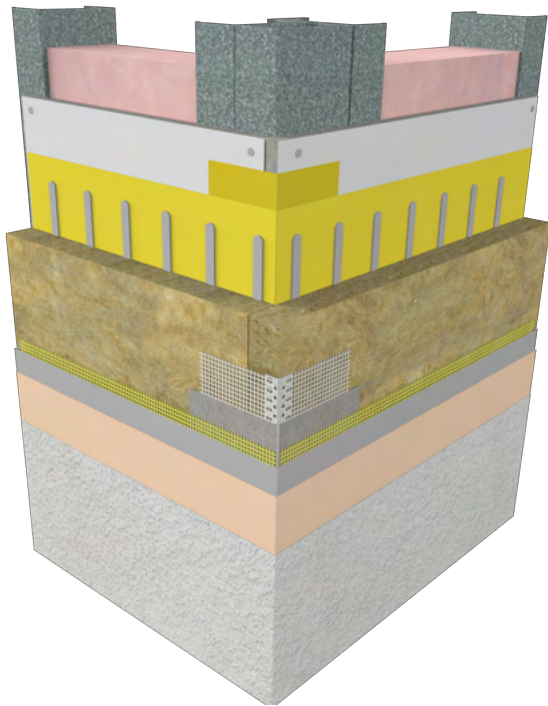

Figure 50

### Outside Corners

Sto-Mesh Corner Bead is necessary to achieve impact resistant corners (e.g. outside building corners, pilasters, door returns) and helps to achieve straight/true corners.

1. Apply base coat to both sides of the outside corner by trowel to an approximate thickness of 1/8" (3mm) and slightly wider and longer than the accessory dimensions.
2. Immediately place the accessory directly into the wet base coat.
3. Press the accessory into place with the trowel.
4. Embed and completely cover the mesh and PVC by troweling from the corner to the edge of the mesh. Avoid excess build-up of base coat and feather along edges. Make sure no mesh or PVC color is visible after the base coat is dry. If visible apply additional base coat to completely hide the mesh/PVC color.
5. Adjoin separate pieces of corner bead by abutting PVC to PVC and overlapping the mesh "tail" from one piece onto the next piece.
6. Fully embed the accessory and mesh "tail" in base coat.

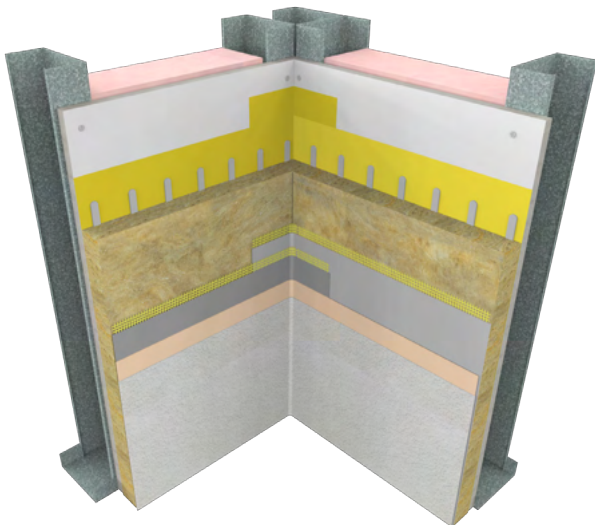

Figure 51

### Inside Corners

1. Apply base coat to both sides of the inside corner by trowel to an approximate thickness of 1/8" (3mm).
2. Immediately place the mesh directly into the wet base coat. Double wrap the inside corner by installing another layer of mesh minimum 8" (200mm) in the opposite direction. Press the mesh into place with the trowel.
3. Embed and completely cover the mesh by troweling from the corner to the edge of the mesh. Use an inside corner trowel for best results. Make sure no mesh color is visible after the base coat is dry. If visible apply additional base coat to completely hide the mesh color.



Figure 52

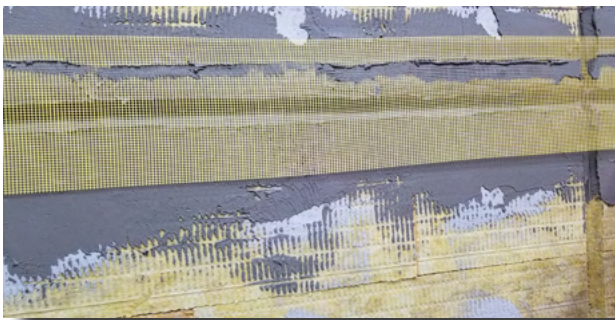

Figure 53



Figure 54

### Reveals

1. Apply base coat to all sides of the reveal and onto the face of the insulation board surface to an approximate thickness of 1/8" (3mm) (Figure 52).
2. Immediately place the mesh directly into the wet base coat (Figure 53).
3. Press the mesh into place with the trowel.
4. Embed and completely cover the mesh by troweling from the depth of the reveal to the edge of the mesh (Figure 54). Avoid excess build-up of base coat and feather along mesh edges. Make sure no mesh color is visible after the base coat is dry. If visible apply additional base coat to completely hide the mesh color.

For best results, use a tool that matches the profile of the reveal to make the base coat smooth in the reveal and around edges.

**NOTE:** Do not use wet brushes when tooling reveals.

## Base Coat Installation with Reinforcing Mesh

Several grades (weights) of reinforcing mesh are available to achieve increasing levels of impact resistance (as measured in accordance with ASTM E2486) when embedded in base coat:

IMPACT RESISTANCE LEVEL (in accordance with ASTM E2486)	Reinforcing Mesh needed to achieve Impact Resistance levels
<p align="center"><b>Standard:</b> 25-49 in-lb (2.8-5.6 J)</p>	<p>Pass with one layer Sto Mesh (4.5 oz/yd<sup>2</sup>)</p>
<p align="center"><b>Medium:</b> 50-89 in-lb (5.7-10.1 J)</p>	<p>Pass with one layer Sto Mesh (4.5 oz/yd<sup>2</sup>)</p>
<p align="center"><b>High:</b> 90-150 in-lb (10.2-17.0 J)</p>	<p>Pass with one layer Sto Mesh (6 oz/yd<sup>2</sup>)</p>
<p align="center"><b>Ultra-High:</b> Over 150 in-lb (&gt;17.0 J)</p>	<p>Pass with one layer Sto Intermediate Mesh (11 oz/yd<sup>2</sup>)</p>

Ultra-High impact resistance is recommended for use at ground floors and other areas subject to impact or abuse. Areas with special impact resistance requirements (other than Medium) should be designated on architectural drawings.

1. Apply base coat to the insulation board surface to a rough thickness of approximately 1/8" (3mm) in widths slightly wider than the mesh.
2. Immediately place mesh into the wet base coat and press the mesh into place by troweling from the center to the edges of the mesh.
3. Spread the base coat across the surface of the mesh to completely embed the mesh and to achieve a smooth uniform surface approximately 1/16" (1.6mm) thick.
4. Overlap mesh seams minimum 2-1/2" (64mm) and feather base coat at seams.

Some mesh pattern may be visible in certain areas of the base coat. This will be addressed/rectified with the skim coat application.

### Skim Coat

After the initial application of base coat with reinforcing mesh dries, apply a second coat of base coat to fill low spots and to level the wall in preparation for application of the finish coat. Prior to skim coat application, use the straight edge of a trowel or rubbing stone to scrape/rub any ridges or trowel marks remaining from the initial base coat application.

## 8. Finish Application

Allow base coat to dry completely before applying primer or finish.

Before starting the primer or finish application, use the straight edge of a trowel or rubbing stone to scrape/rub any ridges or trowel marks remaining from the skim coat application.

### Primer Application

The primer is an optional component (except for some specialty finishes) which reduces surface water absorption of the base coat, and enhances finish color, texture, and coverage. If primer is used, apply an even coat of the primer with a ½" (13 mm) or ¾" (19mm) nap roller to the base coat and allow to dry before applying finish.

### Textured Finish Preparation

- Plan, organize, and stage finish application for the best possible result.
- Schedule finish application with weather forecast and weather conditions in mind. Do not install finish in wet or freezing weather or if rain, hail, snow, or freezing weather is imminent.
- Store finish in shade or inside at room temperature conditions. Avoid installing separate batches of finish side-by-side, as minor shade variations can occur between batches. Apply separate batches at changes in plane.
- Avoid application of finish in direct sunlight which can result in shadow lines from scaffolding because of different drying rates of the finish in shade versus in direct sun. Application in direct sun or in extremely hot weather accelerates drying of the finish and limits working time to apply and float the finish, which can result in non-uniform finish texture. Cool or damp weather will extend drying time and may require added measures of protection against wind, dust, dirt, rain and freezing while the finish is still drying.



Figure 55

## Application

1. Stage the project with sufficient personnel to enable continuous application of the finish across and down the wall to an architectural break such as a change in a plane, a build-out, or aesthetic reveal.
2. Apply finish with a stainless steel trowel to the base coat (or primed base coat) surface. Apply to a rough thickness slightly larger than the aggregate size in the finish and then scrape the finish down with the trowel to the thickness of the aggregate. Float the finish with a plastic float in a figure eight motion (Figure 55) to achieve the final texture. Work to an architectural break across and down the wall in this manner to avoid cold joints in the finish.
3. Apply finish to base coat (or primed base coat) only.  
**NOTE:** Do not apply over irregular or unprepared surfaces, joint sealants, caulking, metal, or other foreign surfaces.
4. Specialty finishes: for specialty finishes such as Stolit Milano, Sto Decocoat, Sto Granitex, Sto Creativ Granite, Sto Creativ Brick, and Sto Creativ Lux, refer to the respective product bulletins in the Documentation Center at <http://www.stocorp.com>



## 9. Precautions and Limitations

- Standard insulation board thickness: 2, 3 or 4 inches (51, 76, or 102mm).
- Keep insulation board dry during construction and while in service. R-value, adhesion and other properties can be compromised if insulation stays wet. Protect with tenting, base coat, or other protection to maintain insulation board integrity and properties.
- Wind load resistance: structural back-up wall assembly must be designed for maximum allowable deflection of  $L/240$ , normal to the plane of the wall. Stud spacing: 16 inches (406mm) on center maximum. Ultimate wind load resistance: positive 253 lb/ft<sup>2</sup> (12.1 lb/ft<sup>2</sup>), negative 126 lb/ft<sup>2</sup> (-6.03kPa). Refer to StoTherm ci Design Guide for fastening details to achieve ultimate loads.
- Impact resistance: heavy reinforcing mesh layer (11 oz/yd<sup>2</sup> [373 g/m<sup>2</sup>]) or other design adjustments are recommended for ground floors and other areas at risk of impacts or abuse.
- Not for use on horizontal or low slope surfaces, below grade, roofs or roof-like surfaces, or in areas of water immersion, pooling or ponding water. For use on vertical above grade walls only.
- Aesthetics: slight surface irregularities may be apparent in the finished wall surface for brief periods during the day in critical light. Smooth or fine texture finishes are discouraged. Minimum 1.5 mm (Medium) or heavier textures are preferred to hide surface imperfections. On some occasions surface mount dowels may “read” through the finished wall surface as the building ages. This can be remedied by recoating (or prevented by using countersunk dowels).
- Air Barrier, insulation board, and base coat materials are not intended for permanent weather exposure. Refer to specific component product bulletins and packaging for other limitations that may apply involving use, handling and storage of component materials.